

LOHR RAILWAY SYSTEM

ROAD ON RAIL



www.lohr.fr



LOHR UIC wagon: A new generation to cross Europe

New improvements:

- Access to all the main lines in Europe with standard 4m high semi-trailers.

Most of the semi-trailers in Europe are not compatible with conventional combined transport.

LOHR System is specially design for horizontal loading standards semi-trailers.

LOHR UIC wagon is the only one that is suitable for the transport of 4m height semi-trailers on French, Spanish and UK markets.

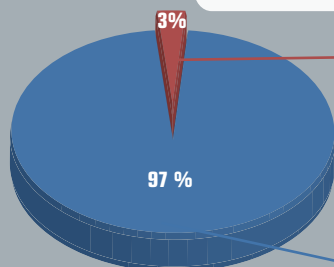
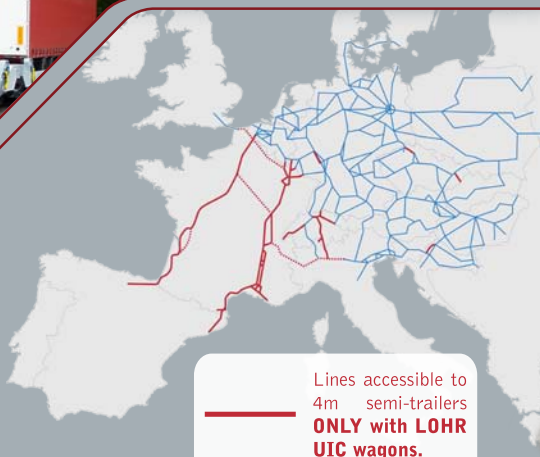

About 50 000 specifics semi-trailers cranable in Europe (compatible with conventional vertical loading)



1 830 000 non-cranable standards semi-trailers in Europe (only compatible with horizontal loading)

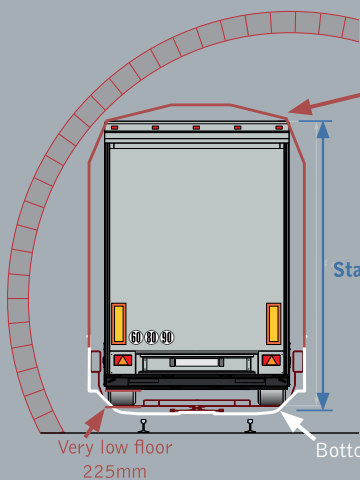

- Bottom profile according UIC 505-1, loading platform height 225 mm

The LOHR UIC wagon is completely in accordance with UIC 505-1 bottom gauge and can therefore travel everywhere in Europe.

- Compatible with vertical loading/unloading in traditional existing combined transport terminals.

